

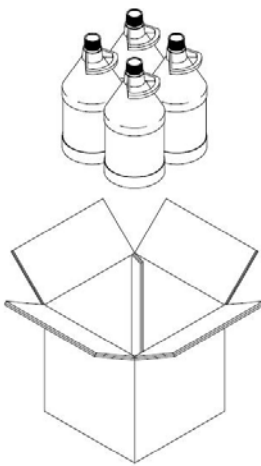



Package: Beta Bottle Issue Date: July 1, 2009 Revision: New UN Cert +BV1289

| NO. / CASE | LIST OF COMPONENTS | CONFIGURATION | SPEC / PART # |
|------------|-------------------------------------------------------------|---------------|---------------|
| 4 | Rexam 38-439 A Stock Acid Closures with Foam Liner | A, B, C & D | IM-317-4937 |
| 4 | 9 Pint Beta Bottles with 38-439 Neck Finish and Handle | A, B, C & D | |
| 8 | Liner Bags | C & D | |
| 1 Roll | Red Vinyl Self Adhesive Tape | C & D | |
| (1) | Regular Slotted Corrugated Container, Pre-assembled | A, B, C & D | |
| (1) Roll | 2" Clear Pressure Sensitive Tape (Scotch 3M Packaging Tape) | A, B, C & D | |
| Adhesive | SETCO Waterproof Thermoset Adhesive System | A & C | |

| PACKAGING CONFIGURATIONS: | Case Sealing Method |
|--------------------------------------------------------|-----------------------------------------------------------------------------------|
| Configuration A: 4 x 9 Pint Bottles without Liner Bags | Top: 2" Clear Pressure Sensitive Tape Bottom: Glued |
| Configuration B: 4 x 9 Pint Bottles without Liner Bags | Top: 2" Clear Pressure Sensitive Tape Bottom: 2" Clear Pressure Sensitive Tape |
| Configuration C: 4 x 9 Pint Bottles with Liner Bags | Top: 2" Clear Pressure Sensitive Tape Bottom: Glued |
| Configuration D: 4 x 9 Pint Bottles with Liner Bags | Top: 2" Clear Pressure Sensitive Tape Bottom: 2" Clear Pressure Sensitive Tape |

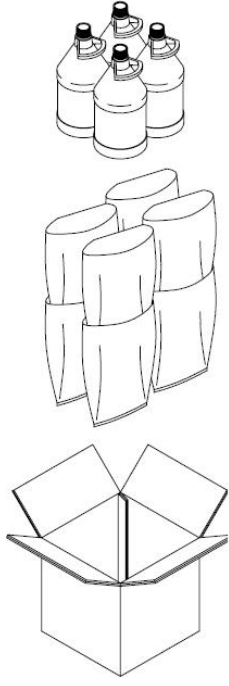
| ASSEMBLY INSTRUCTIONS: | Configuration A & B | Configuration C & D |
|-----------------------------------------------------------------------------------------------------------------------------------------------------------------------------------------------------------------------------------------------------------------------------------------------------------------------------------------------------------------------------------------------------------------------------------------------------------------------------------------------------------------------------------------------------------------------------------------------------------------------------------------------------------------------------------------------------------------------------------------------------------------------------------------------------------------------------------------------------------------------------------------------------------------------------------------------------------------------------------------------------------------------------------------------------------------------------------------------------------------------------------------------------------------------------------------------------------------------------------------------------------------------------------------------------------------------------------------------------------------------------------------------------------------------------------------|---------------------------------------------------------------------------------------------------------------------------------------------------------------------------------------------------------------------|---------------------------------------------------------------------------------------|
| <p>Note: Refer to component list above. Examine all parts for defects. Once you have determined that this packaging is free from defects then follow these instructions for package assembly.</p> <p>1. Apply the threaded closure with an application torque in the range of 35 to 50 in/lbs using an appropriate closing tool.</p> <p>Configuration C & D (with Liner Bag)</p> <ol style="list-style-type: none"> Place one liner bag into another. Place the bottle into the bag with the closure facing upward towards the opening in the bag. Twist the neck of the bag closed Wrap a 1-1/2" to 2" long piece of the red vinyl tape around the neck of the bag and pinch the two adhesive sides of the tape together. <p>2. Place four (4) bottles (with or without liner bag) into the pre assembled box with the bottle closures facing upward, in a 2 x 2 configuration.</p> <p>3. Fold the minor top flaps (A) in first. Next fold the major top flaps (B).</p> <p>4. Tape the top flaps closed with 2" clear pressure sensitive tape. Center the tape over the middle seam formed by the flaps being folded together. The length of the tape should be such that there is a 2" extension on each end.</p> <p>5. Apply product labels and DOT hazard warning labels as required by work order instructions. Do not cover up any UN markings with labels or tape of any kind.</p> |   <p>4G/Y32.3/S/** USA+BV1289</p> |  |

** (Year of Manufacture)