

**UNITED NATIONS / DOT  
PERFORMANCE CERTIFICATION**



**4G DESIGN QUALIFICATION**

**2 x 2-1/2 Gallon F-Style Plastic Bottle (Marlex Resin)**

**Packaging with Two Liner Options:**

**#1: PE Foam**

**#2: Induction Sealed Liner**

**TEST REPORT #: 09-7006**



4G / Y35.5 / S / \*\*  
USA / +AA4377

\*\* Insert year the packaging is manufactured

**TESTING PERFORMED FOR:**

**API KIRK CONTAINERS**

2131 S. Garfield Ave.  
Commerce, CA 90040

**ATTN: Arthur Marounian**

**TESTING PERFORMED BY:**

**TEN-E Packaging Services, Inc.**

1666 County Road 74  
Newport, MN 55055

**Phone:** (651) 459-0671

**Fax:** (651) 459-1430

**TEN-E Packaging Services, Inc.**

326 N. Corona Avenue  
Ontario, CA 91764

**Phone:** (909) 937-1260

**Fax:** (909) 937-1262

March 19, 2009



**SECTION I: CERTIFICATION**

**Design Qualification of the API Kirk Containers  
2 x 2-1/2 Gallon F-Style Plastic Bottle (Marlex Resin) Packaging with Two Liner Options:  
#1) PE Foam and #2) Induction Sealed Liner**

TEN-E PACKAGING SERVICES, INC. certifies that the **API Kirk Containers** packaging referenced above has passed the standards of the DEPARTMENT OF TRANSPORTATION'S TITLE 49 CFR; Performance Oriented Packaging Standards, Section 178. This package is also certified under IMDG, ICAO/IATA Regulations and the UN Recommendations on the Transport of Dangerous Goods. It is the responsibility of the end user to determine authorization for use under these regulations. The use of other packaging methods or components other than those documented in this report may render this certification invalid.

**SUMMARY OF PERFORMANCE TESTS**

| UN /DOT TEST                               | CFR REFERENCE | TEST LEVEL         | TEST CONTENTS   | TEST COMPLETED                       | TEST RESULTS |
|--|---------------|--------------------|---|--------------------------------------|--------------|
| Drop                                       | 178.603       | 1.6m               | Methanol / Water  | January 21, 2009                     | PASS         |
| Stacking                                   | 178.606       | 771.1 Kg – 24 Hrs. | Water   | January 20, 2009                     | PASS         |
| Pressure #1                                | 173.27        | 95 kPa – 30 Min.   | Water   | January 21, 2009                     | PASS         |
| Pressure #2                                | 173.27        | 95 kPa – 30 Min.   | Water   | January 26, 2009                     | PASS         |
| Vibration                                  | 178.608       | 3.6 Hz – 1 Hr.     | Water   | January 21, 2009                     | PASS         |
| Cobb                                       | 178.516       | 30 minutes         | ---   | January 26, 2009                     | PASS         |
| <b>TEST REPORT NUMBERS:</b>                |               |                    | <b>09-7006, 06-7169, 04-7167</b>  |                                      |              |
| <b>UN MARKING:<br/>(CFR 49 - 178.503)</b>  |               |                    |  | 4G / Y35.5 / S / **<br>USA / +AA4377 |              |
| <b>PACKAGING IDENTIFICATION CODE:</b>      |               |                    | 4G - Fiberboard Box (178.516)   |                                      |              |
| <b>PERFORMANCE STANDARD:</b>               |               |                    | Y (Packaging meets Packing Group II and III tests)                                  |                                      |              |
| <b>AUTHORIZED GROSS MASS:</b>              |               |                    | 35.5 Kg (78.2 Lbs.)   |                                      |              |
| <b>"S" DESIGNATION:</b>                    |               |                    | Denotes Inner Packagings  |                                      |              |
| <b>YEAR OF MANUFACTURE:</b>                |               |                    | **Insert year the packaging is manufactured   |                                      |              |
| <b>STATE AUTHORIZING THE MARK:</b>         |               |                    | USA   |                                      |              |
| <b>PACKAGING CERTIFICATION AGENCY:</b>     |               |                    | (+AA) TEN-E Packaging Services, Inc. (Ontario, CA)                                  |                                      |              |
| <b>THIRD PARTY PACKAGE IDENTIFICATION:</b> |               |                    | +AA4377   |                                      |              |
| <b>PERIODIC RETEST DATE:</b>               |               |                    | January 26, 2011  |                                      |              |

ALL OTHER WARRANTIES, EXPRESSED OR IMPLIED, INCLUDING ANY WARRANTY THAT THE PACKAGING TESTED IS MERCHANTABLE OR FIT FOR A PARTICULAR PURPOSE, ARE DISCLAIMED. In no event shall TEN-E Packaging Services, Inc. liability exceed the total amount paid by **API Kirk Containers** for services rendered. In the event of future changes to the above referenced test standard, it is the responsibility of **API Kirk Containers** to determine whether additional testing or updating of past testing is necessary to verify that the packaging we have tested remains in compliance with those standards.

**MANUFACTURER:**

**API Kirk Containers**  
2131 S. Garfield Ave.  
Commerce, CA 90040

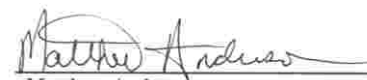

Matthew Anderson  
Packaging Engineer  
TEN-E Packaging Services, Inc.  
326 North Corona Avenue  
Ontario, CA 91764

**SECTIONS II & V: PACKAGING DESCRIPTION / COMPONENT DRAWINGS**

**2 x 2-1/2 Gallon F-Style Plastic Bottle (Marlex Resin) Packaging with Two Liner Options:  
#1) PE Foam and #2) Induction Sealed Liner**

| ASSEMBLY DRAWING     | TEST LEVELS   |                                 |
|----------------------|---|---------------------------------|
|                      | Certification Type:                                     | Design Qualification            |
|                      | Packaging Code Designation:                             | 4G                              |
|                      | Packing Group:  | II                              |
|                      | Specific Gravity:                                       | 1.6                             |
|                      | Internal Pressure:                                      | 95 kPa                          |
|                      | <b>TEST SAMPLE PREPARATION</b><br>(Refer to Section IV) |                                 |
|                      | Overall Packaging Tare Weight:                          | 1,422 Grams                     |
|                      | Inner Packaging Fill Capacity (98% Maximum Capacity):   |                                 |
|                      | Methanol/Water  | 10,616 Grams                    |
|                      | Water   | 10,945 Grams                    |
|                      | Package Test Weight:                                    |                                 |
|                      | Methanol/Water  | 22.6 Kg (49.8 Lbs.)             |
|                      | Water   | 23.3 Kg (51.3 Lbs.)             |
|                      | Authorized Package Gross Mass:                          | 36.4 Kg (80.2 Lbs.)             |
|                      | <b>CLOSING METHODS – INNER PACKAGING</b>                |                                 |
|                      | Application Torque                                      | 75 In-Lbs                       |
|                      | Equipment:  | Snap on Torque Wrench #702      |
|                      | <b>CLOSING METHODS – SHIPPER</b>                        |                                 |
|                      | <b>Top Flaps:</b>                                       |                                 |
|                      | Type:   | 3M #375 Pressure Sensitive Tape |
| Width:               | 48 mm (2")  |                                 |
| Overlap:             | 2" Minimum  |                                 |
| Tape Pattern:        | Center Seam   |                                 |
| Inner Flaps:         | 4-1/2" Width Gap  |                                 |
| Outer Flaps:         | Meet  |                                 |
| <b>Bottom Flaps:</b> |   |                                 |
| Type:                | 3M #375 Pressure Sensitive Tape                         |                                 |
| Width:               | 48 mm (2")  |                                 |
| Overlap:             | 2" Minimum  |                                 |
| Tape Pattern:        | Center Seam   |                                 |
| Inner Flaps:         | 4-1/2" Width Gap  |                                 |
| Outer Flaps:         | Meet  |                                 |

**For Packagings with an Established Gross Mass:**

If the gross mass calculation in this report exceeds the previously established gross mass, the manufacturer may elect to maintain the current gross mass marking (e.g. the gross mass rating of the UN marking on the packaging may be less than the calculated gross mass indicated in this report) or use the newly established gross mass. In no event shall the gross mass marking on the packaging exceed the gross mass to which the packaging was tested.

| CLOSURE   |   |                                   | Drawing |
|---|---|-----------------------------------|---------|
| Manufacturer: Rieke Corporation Auburn, IN(Rieke Dwg #28000449, 1/7/94) |   |                                   |         |
| Component Information   | Specification Information   | Quality Control Audit             |         |
| Description:  | 63mm Threaded Closure, Ribbed                                       |                                   |         |
| Material/Pigment:   | Copolymer   | Polypropylene / White             |         |
| Density:  |   | 0.887 g/cc                        |         |
| Tare Weight:  |   | 14.07 Grams                       |         |
| Overall Dimensions:   |   |                                   |         |
| • Height  | 0.725" ± 0.008"   | 0.854"                            |         |
| • Outside Diameter  | 2.757" ± 0.012"   | 2.777"                            |         |
| Thread:   |   |                                   |         |
| • Type  | 63  |                                   |         |
| • Style   | FS-632  |                                   |         |
| Finish Dimensions:  |   |                                   |         |
| • T   | 2.541" ± 0.013"   | 2.548"                            |         |
| • E   | 2.389" ± 0.011"   | 2.370"                            |         |
| • Thread Pitch  | 0.167"  |                                   |         |
| Markings (QC Audit):  | Rieke   |                                   |         |
| LINER (Option #1)   |   |                                   |         |
| Component Information   | Specification Information   | Quality Control Audit             |         |
| Description:  | Polyethylene Foam Liner   |                                   |         |
| Tare Weight:  |   | 1.15 Grams                        |         |
| Thickness:  |   | 0.035"                            |         |
| Diameter:   |   | 2.372"                            |         |
| LINER (Option #2)   |   |                                   |         |
| Component Information   | Specification Information   | Quality Control Audit             |         |
| Description:  | Pulp / Foil Induction Sealed Liner                                  |                                   |         |
| Tare Weight:  |   | 1.85 Grams                        |         |
| Thickness:  |   | 0.041"                            |         |
| Diameter:   |   | 2.375"                            |         |
| BOTTLE (Mold # 200 Series)  |   |                                   |         |
| Manufacturer: API Kirk Container: Commerce, CA                          |   |                                   |         |
| Component Information   | Specification Information   | Quality Control Audit             |         |
| Description:  | 2-1/2 Gallon (10 Liter) F-Style Plastic Bottle                      |                                   |         |
| Material/Pigment:   | High Density Polyethylene / White (Marlex Resin 9512H)              | High Density Polyethylene / White |         |
| Method of Mfgr:   | Blow Molded   | Blow Molded                       |         |
| Density:  | 0.954 g/cm <sup>3</sup>   | 0.951 g/cc                        |         |
| Melt Index (190/21.6):  |   | 29.58 g/10 minutes                |         |
| Tare Weight:  |   | 350 Grams                         |         |
| Capacity:   |   |                                   |         |
| • Rated   | 2-1/2 Gallon (10 Liters)  |                                   |         |
| • Overflow  |   | 11,168 Grams (2.950 Gallons)      |         |
| Overall Dimensions:   |   |                                   |         |
| • Height  | 14.43"  | 14-1/2"                           |         |
| • Width   | 6.51"   | 6.789"                            |         |
| • Depth   | 8.84"   | 8.896"                            |         |
| Finish Dimensions:  |   |                                   |         |
| • T   |   | 2.542"                            |         |
| • E   |   | 2.334"                            |         |
| • Thread Pitch  |   | 0.1623"                           |         |
| Wall Thickness:   |   |                                   |         |
| • Nominal   |   |                                   |         |
| • Minimum   |   | 0.022"                            |         |
| Markings (QC Audit):  | HDPE 10 Liter 2.5 U.S. GALLONS 10/08<br>API Kirk Containers No. 204 |                                   |         |

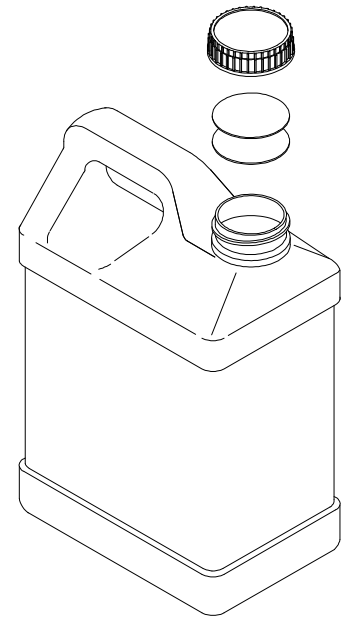







| SHIPPER  |   |  |
|--|---|--|
| Manufacturer: Temple-Inland: Ontario, CA       |   |  |
| Component Information                          | Specification Information   | Quality Control Audit                                      |
| <b>Description:</b>                            |   | Regular Slotted Container                                  |
| <b>Die-Cut Hand Holes:</b>                     |   |  |
| • <b>Dimensions (Length x Width)</b>           |   | 3.457" x 1.032"  |
| • <b>Location</b>                              |   | Short Side Of Shipper                                      |
| <b>Material/Flute (Inner to Outer):</b>        | 51ECT Double Wall Mottled White Corrugated Fiberboard; B/C-Flute  | Double Wall Mottled White Corrugated Fiberboard; B/C-Flute |
| <b>Basis Weight (Outer to Inner) Lbs./MSF:</b> |   | 46.8/26.8/41.8/28.3/45.6                                   |
| <b>Combined Wt. of Facings:</b>                |   | 134.2  |
| <b>Tare Weight:</b>                            |   | 711 Grams  |
| Dimensions                                     | Inside  | Outside  |
| • <b>Length:</b>                               |   | 14"  |
| • <b>Width:</b>                                |   | 9-5/8"   |
| • <b>Height:</b>                               |   | 15-1/2"  |
| <b>Board Caliper (Nominal) :</b>               |   | 0.264"   |
| <b>Manufacturer's Joint:</b>                   |   | Inside Glued, 1-3/8" Lap                                   |
| <b>Markings (QC Audit):</b>                    | <div style="display: flex; align-items: center;"> <div style="border: 1px solid black; border-radius: 50%; width: 20px; height: 20px; display: flex; flex-direction: column; justify-content: center; align-items: center; margin-right: 5px;"> <span style="font-size: 8px;">u</span> <span style="font-size: 8px;">n</span> </div> <div> <p>4G/Y35.5/S/08<br/>USA/+AA4377</p> </div> </div> | 154/155  |
| Box Drawing                                    | Box Certificate   | Flute Drawing  |
|  | <div style="border: 1px solid black; padding: 10px; width: fit-content; margin: auto;"> <p style="text-align: center;">GUARANTEED<br/>EDGE CRUSH 51 LBS/IN<br/>TEST (ECT)<br/>MFG. BY<br/>TEMPLE-INLAND<br/>ONTARIO, CA U.S.A.</p> </div>   |  |

**SECTION III: TEST PROCEDURES AND RESULTS**

**DROP TESTS**

| TEST INFORMATION   | CRITERIA FOR PASSING THE TEST   |
|--|---|
| <p><b>TEST CONTENTS:</b> Methanol/Water Solution (0.97 SG)</p> <p><b>SAMPLE PREPARATION:</b> Refer to Section II</p> <p><b>CONDITIONING:</b> -18°C (0°F), Chamber #201</p> <p><b>TEST CONTENTS TEMP.:</b> -18.1° (-0.58°F)</p> <p><b>DROP HEIGHT:</b> 1.6 Meters (63")<br/>(Refer to Section IV)</p> <p><b>TEST EQUIPMENT:</b> L.A.B. Accu Drop 160 #301</p> | <ul style="list-style-type: none"> <li>• For packaging containing liquid, each packaging does not leak.</li> <li>• There can be no damage to the outer packaging likely to adversely affect safety during transport and there is no leakage of the filling substance from the inner packaging.</li> <li>• Any discharge from a closure is slight and ceases immediately after impact with no further leakage.<br/>(§178.603)</li> </ul> |

**DROP ORIENTATIONS & TEST RESULTS**

| Sample #1: Flat on Bottom   | Sample #2: Flat on Top  | Sample #3: Flat on Long Side  |
|---|---|---|
|  |  |    |
| <p><b>PASS:</b> No leakage or damage.</p>   | <p><b>PASS:</b> No leakage or damage.</p>   | <p><b>PASS:</b> No leakage or damage.</p>   |
| Sample #4: Flat on Short Side   | Sample #5: Bottom Corner  | *Sample #1&5: Top Corner  |
|  |  |    |
| <p><b>PASS:</b> No leakage or damage.</p>   | <p><b>PASS:</b> No leakage. Slight deformation at impact corner.</p>                | <p><b>PASS:</b> No leakage. Slight deformation at impact corner.<br/>(two drops conducted one with each closure/liner in impact corner)</p> |

\*Sample used for Flat on Bottom & Bottom Corner Drop is also used for the Top Corner Drop

**STACKING & STACKING STABILITY TESTS**

| TEST INFORMATION   |  | CRITERIA FOR PASSING THE TEST |
|--|--|-------------------------------|
| <b>TEST CONTENTS:</b> Water<br><b>SAMPLE PREPARATION:</b> Refer to Section II<br><b>CONDITIONING:</b> 73°F / 50% RH, Chamber #202<br><b>TEST LOAD APPLIED:</b> 771.1 Kg (1,700.0 Lbs.)<br>(Refer to Section IV)<br><b>TEST DURATION:</b> 24 Hours<br><b>TEST EQUIPMENT:</b> L.A.B. Validator Compression System #403 | <ul style="list-style-type: none"> <li>• There must be no leakage of the filling substance from the inner receptacle, or inner packaging.</li> <li>• There can be no deterioration that could adversely affect transport safety or any distortion liable to reduce the package's strength, cause instability in stacks of packages, or cause damage to inner packagings that is likely to reduce safety in transport.</li> </ul> |                               |
|  |  | (\$178.606)                   |

**STACKING TEST SET UP AND RESULTS**

|  | Sample # | Maximum Deflection After 24 Hours | Results |
|---|----------|-----------------------------------|---------|
|   | 6        | 0.153"                            | PASS    |
| 7   | 0.153"   | PASS                              |         |
| 8   | 0.153    | PASS                              |         |

**STACKING STABILITY TEST SET-UP**      **CRITERIA FOR PASSING THE TEST**

|   |   |
|---|---|
|  | In guided load tests, stacking stability must be assessed after test completion. <ul style="list-style-type: none"> <li>• Two filled packagings of the same type must be placed on the test sample.</li> <li>• The stacked packages must maintain their position for one hour.</li> </ul> (\$178.606) |
| <b>PASS</b>   |   |

**PRESSURE DIFFERENTIAL TEST**

**PE Foam Liner**

| TEST INFORMATION               |                                      | CRITERIA FOR PASSING THE TEST  |
|--------------------------------|--------------------------------------|--|
| <b>TEST CONTENTS:</b>          | Water                                | <ul style="list-style-type: none"> <li>Packaging for which retention of liquid is a basic function must be capable of withstanding the pressure requirements without leakage.<br/>(§173.27)</li> </ul> |
| <b>FILL CAPACITY:</b>          | Maximum Capacity                     |  |
| <b>CLOSURE APPLICATION:</b>    | Refer to Section II                  |  |
| <b>CONDITIONING:</b>           | Ambient                              |  |
| <b>TEST PRESSURE:</b>          | 95 kPa                               |  |
| <b>TEST DURATION:</b>          | 30 Minutes                           |  |
| <b>AREA OF PRESSURIZATION:</b> | Through the Bottom                   |  |
| <b>TEST EQUIPMENT:</b>         | Regulated Water Source<br>Gauge #602 |  |

**HYDROSTATIC PRESSURE TEST SET-UP & RESULTS**

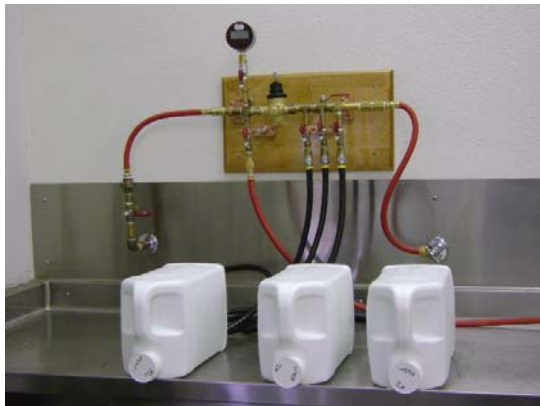

| Sample # | Results | Comments / Observations   |
|----------|---------|---|
| 1        | PASS    | All three samples maintained the 95 kPa test pressure for 30 minutes without leakage. |
| 2        | PASS    |   |
| 3        | PASS    |   |

**PRESSURE DIFFERENTIAL TEST** **Induction Sealed Liner**

| TEST INFORMATION   | CRITERIA FOR PASSING THE TEST  |
|--|--|
| <p><b>TEST CONTENTS:</b> Water</p> <p><b>FILL CAPACITY:</b> Maximum Capacity</p> <p><b>CLOSURE APPLICATION:</b> Refer to Section II</p> <p><b>CONDITIONING:</b> Ambient</p> <p><b>TEST PRESSURE:</b> 95 kPa</p> <p><b>TEST DURATION:</b> 30 Minutes</p> <p><b>AREA OF PRESSURIZATION:</b> Through the Bottom</p> <p><b>TEST EQUIPMENT:</b> Regulated Water Source<br/>Gauge #602</p> | <ul style="list-style-type: none"> <li>• Packaging for which retention of liquid is a basic function must be capable of withstanding the pressure requirements without leakage.<br/>(§173.27)</li> </ul> |

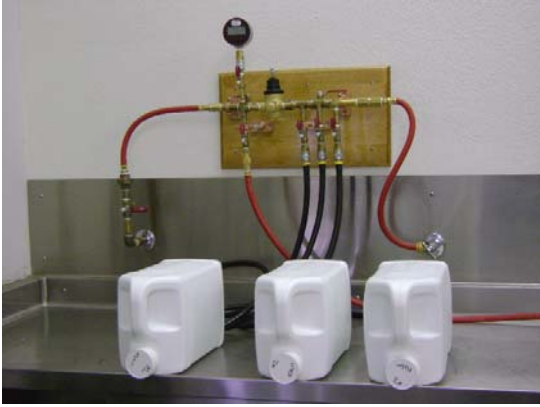
| HYDROSTATIC PRESSURE TEST SET-UP & RESULTS  |          |         |   |
|---|----------|---------|---|
|   | Sample # | Results | Comments / Observations   |
|  | 1        | PASS    | All three samples maintained the 95 kPa test pressure for 30 minutes without leakage. |
|   | 2        | PASS    |   |
|   | 3        | PASS    |   |

**REPETITIVE SHOCK VIBRATION TESTS**

| TEST INFORMATION   | CRITERIA FOR PASSING THE TEST  |
|--|--|
| <p><b>TEST CONTENTS:</b> Water</p> <p><b>SAMPLE PREPARATION:</b> Refer to Section II</p> <p><b>CONDITIONING:</b> 73°F / 50% RH, Chamber #202</p> <p><b>TABLE DISPLACEMENT:</b> 1"</p> <p><b>TEST FREQUENCY:</b> 3.6 Hz</p> <p><b>TEST DURATION:</b> 1 Hour</p> <p><b>TEST EQUIPMENT:</b> Vertical motion using<br/>L.A.B. Palletizer Transportation<br/>Simulator #501</p> | <p>Immediately following the period of vibration, each package must be removed from the platform, turned on its side and observed for any evidence of leakage.</p> <ul style="list-style-type: none"> <li>• A packaging passes the vibration test if there is no rupture or leakage from any of the packages.</li> <li>• No test sample should show any deterioration which could adversely affect transportation safety or any distortion liable to reduce packaging strength. (\$178.608)</li> </ul> |

**VIBRATION TEST SET-UP & RESULTS**

|  | Sample # | Results | Comments / Observations |
|---|----------|---------|-------------------------|
|   | 6        | PASS    | No leakage or damage.   |
|   | 7        | PASS    |                         |
|   | 8        | PASS    |                         |

**COBB WATER ABSORPTION TESTS**

| TEST INFORMATION       |   | CRITERIA FOR PASSING THE TEST   |
|------------------------|---|---|
| <b>SAMPLE SIZE:</b>    | (5) 5" x 5" Squares   | <ul style="list-style-type: none"> <li>An increase in mass greater than 155 g/m<sup>2</sup> over the 30 minute duration represents an unacceptable level of water resistance.<br/>(§178.516)</li> </ul> |
| <b>CONDITIONING:</b>   | 73°F / 50% RH, Chamber #202   |   |
| <b>WATER APPLIED:</b>  | 100 mL / Sample   |   |
| <b>TEST DURATION:</b>  | 30 Minutes / Sample   |   |
| <b>TEST EQUIPMENT:</b> | UWE Analytical Balance #102<br>Gurley Cobb Water Absorption Apparatus |   |

| COBB WATER ABSORPTION TEST RESULTS |                                    |
|------------------------------------|------------------------------------|
| Sample #                           | Water Absorbed (g/m <sup>2</sup> ) |
| 1                                  | 120 g/m <sup>2</sup>               |
| 2                                  | 102 g/m <sup>2</sup>               |
| 3                                  | 133 g/m <sup>2</sup>               |
| 4                                  | 121 g/m <sup>2</sup>               |
| 5                                  | 124 g/m <sup>2</sup>               |
| <b>AVERAGE:</b>                    | 120 g/m <sup>2</sup>               |
| <b>RESULT</b>                      | <b>PASS</b>                        |

**REGULATORY AND INDUSTRY STANDARD REFERENCES**

**REGULATORY REFERENCES**

| TEST              | 49 CFR <sup>①</sup><br>2008<br>Edition | UN <sup>②</sup><br>15th<br>Edition | IMDG <sup>③</sup><br>2008<br>Edition | ICAO <sup>④</sup><br>09-10<br>Edition | IATA <sup>⑤</sup><br>50th<br>Edition |
|-------------------|--|------------------------------------|--------------------------------------|---------------------------------------|--------------------------------------|
| <b>Drop:</b>      | 178.603                                | 6.1.5.3                            | 6.1.5.3                              | 6; 4.3                                | 6.3.3                                |
| <b>Stacking:</b>  | 178.606                                | 6.1.5.6                            | 6.1.5.6                              | 6; 4.6                                | 6.3.6                                |
| <b>Pressure:</b>  | 173.27(c)                              | 4.1.1.4.1                          | ---                                  | 4; 1.1.6                              | 5.0.2.9                              |
| <b>Vibration:</b> | 178.608                                | ---                                | ---                                  | 4; 1.1.1                              | 5.0.2.7                              |
| <b>Cobb:</b>      | 178.516                                | 6.1.4.12.1                         | 6.1.4.12.1                           | 6; 3.1.11.1                           | 6.2.12.2                             |

- ① United States Department of Transportation Code of Federal Regulations (CFR) Title 49, Transportation, Parts 100-199
- ② The United Nations Recommendations on the Transport of Dangerous Goods — Model Regulations. (UN – Orange Book)
- ③ International Maritime Dangerous Goods Code (IMDG)
- ④ Technical Instructions for the Safe Transport of Dangerous Goods by Air (ICAO)
- ⑤ International Air Transport Association (IATA) Dangerous Goods Regulations

**INDUSTRY STANDARD REFERENCES**

|                   |                          |   |
|-------------------|--------------------------|---|
| <b>Drop:</b>      | ASTM <sup>⑥</sup> D5276: | Standard Test Method for Drop Test of Loaded Containers by Free Fall                    |
|                   | ISO <sup>⑦</sup> 2248:   | Packaging – Complete, Filled Transport Packages – Vertical Impact Test By Dropping      |
| <b>Stacking:</b>  | ASTM <sup>⑥</sup> D4577: | Standard Test Method for Compression Resistance of a Container Under Constant Load      |
|                   | ISO <sup>⑦</sup> 2234:   | Packaging – Complete, Filled Transport Packages – Stacking Tests using Static Load      |
| <b>Vibration:</b> | ASTM <sup>⑥</sup> D999:  | Standard Test Method for Vibration Testing of Shipping Containers                       |
|                   | ISO <sup>⑦</sup> 2247:   | Packaging – Complete, Filled transport Packages – Vibration Test at Fixed Low Frequency |
| <b>Cobb:</b>      | ISO <sup>⑦</sup> 535:    | Paper and Board - Determination of Water Absorption - Cobb Method                       |

⑥ American Society for Testing and Materials (ASTM)

⑦ International Organization for Standardization (ISO)

**EQUIPMENT**

All inspection, measuring and test equipment that can affect product quality is calibrated and adjusted at prescribed intervals, or prior to use, and is traceable to NIST, using ANSI Z540 as an overall guide for calibration certification.

**SECTION IV: MATHEMATICAL CALCULATIONS**

**INFORMATION USED FOR CALCULATIONS**

|  |              |                          |
|--|--------------|--------------------------|
| Overall Package Tare Weight (PTW):             | 1,422 Grams  |                          |
| Overflow Capacity (OFC):                       |              | <b>Methanol/Water SG</b> |
| Methanol/Water                                 | 10,833 Grams | <b>SG: 0.970</b>         |
| Water  | 11,168 Grams |                          |
| Number of Inner Packagings (# IP):             | 2            |                          |
| Packing Group                                  | II           |                          |
| Product Specific Gravity (PSG):                | 1.6          |                          |
| Packing Group Multiplication Factor (MF):      | 1.00         |                          |
| Overall Height of one Package (OH):            | 15.63 Inches |                          |
| Stack Test-# of Samples Tested Simultaneously: | 3            |                          |

**98% OF OVERFLOW**

Overflow Capacity (OFC) x 98%

|            |   |            |                     |                |
|------------|---|------------|---------------------|----------------|
| <u>OFC</u> | x | <u>98%</u> |                     |                |
| 10,833     | x | 98% =      | <b>10,616 Grams</b> | Methanol/Water |
| 11,168     | x | 98% =      | <b>10,945 Grams</b> | Water          |

**PACKAGE TEST WEIGHTS**

Overall Pkg Tare Weight (PTW) + (98% Overflow Capacity (OFC) x # of Inner Pkg (# IP))

|                 |   |                  |           |             |                |
|-----------------|---|------------------|-----------|-------------|----------------|
| <u>PTW</u>      | + | <u>(98% OFC)</u> | x         | <u># IP</u> |                |
| 1,422           | + | 10,616           | x         | 2           | Methanol/Water |
| 1,422           | + | 10,945           | x         | 2           | Water          |
| Methanol/Water: |   | <b>22.6</b>      | <b>Kg</b> | <b>49.8</b> | <b>Lbs.</b>    |
| Water:          |   | <b>23.3</b>      | <b>Kg</b> | <b>51.3</b> | <b>Lbs.</b>    |

**AUTHORIZED PACKAGE GROSS MASS CALCULATION (APGM)**

Overall Pkg Tare Weight (PTW) + (Product SG (PSG) x 98% Overflow (OFC) x # of Inner Pkg (# IP))

|            |   |              |           |                |             |             |
|------------|---|--------------|-----------|----------------|-------------|-------------|
| <u>PTW</u> | + | <u>(PSG)</u> | x         | <u>98% OFC</u> | x           | <u># IP</u> |
| 1,422      | + | 1.6          | x         | 10,945         | x           | 2           |
|            |   | <b>36.4</b>  | <b>Kg</b> | <b>80.2</b>    | <b>Lbs.</b> |             |

**DROP HEIGHT**

**Calculation For Product Specific Gravities Exceeding 1.2**

Product Specific Gravity (PSG) x Packing Group Multiplication Factor (MF)

|            |   |             |                    |                             |
|------------|---|-------------|--------------------|-----------------------------|
| <u>PSG</u> | x | <u>MF</u>   |                    | <b>Packing Group: II</b>    |
| 1.6        | x | 1.00        |                    |                             |
|            |   | <b>1.60</b> | <b>Meter</b>       |                             |
|            |   |             |                    | <b>Required Drop Height</b> |
|            |   |             |                    | <b>Actual Drop Height</b>   |
|            |   |             | <b>63.0 Inches</b> | <b>63 Inches</b>            |

**STACKING TEST MINIMUM LOAD CALCULATIONS**

**Number of Packages in a 3m High Stack (118 / Overall Pkg Height (OH) -1)**

118 / Overall Height of one Pkg (OH) - 1

|             |   |            |    |   |                |
|-------------|---|------------|----|---|----------------|
| <u>(118</u> | / | <u>OH)</u> | -1 | = | <u># 3m HS</u> |
| 118         | / | 15.63      | -1 | = | 6.6            |

**Stacking Test Load Calculation (Individual Package)**

Authorized Pkg Gross Mass (APGM) x # of Pkg in a 3m High Stack (# 3m HS)

|             |   |                 |                   |
|-------------|---|-----------------|-------------------|
| <u>APGM</u> | x | <u># 3m HS</u>  |                   |
| 36.4        | x | 6.6             |                   |
|             |   | <b>240.2 Kg</b> | <b>529.5 Lbs.</b> |

**Stacking Test Load Calculation**

Samples x Authorized Pkg Gross Mass (APGM) x # of Pkg in a 3m High Stack (# 3m HS)

|                |   |                 |   |                     |
|----------------|---|-----------------|---|---------------------|
| <u>Samples</u> | x | <u>(APGM</u>    | x | <u># 3m HS)</u>     |
| 3              | x | 36.4            | x | 6.6                 |
|                |   | <b>720.7 Kg</b> |   | <b>1,588.9 Lbs.</b> |