

45 mm CUSTOM NECK FINISH DETAIL
SCALE: 3:1

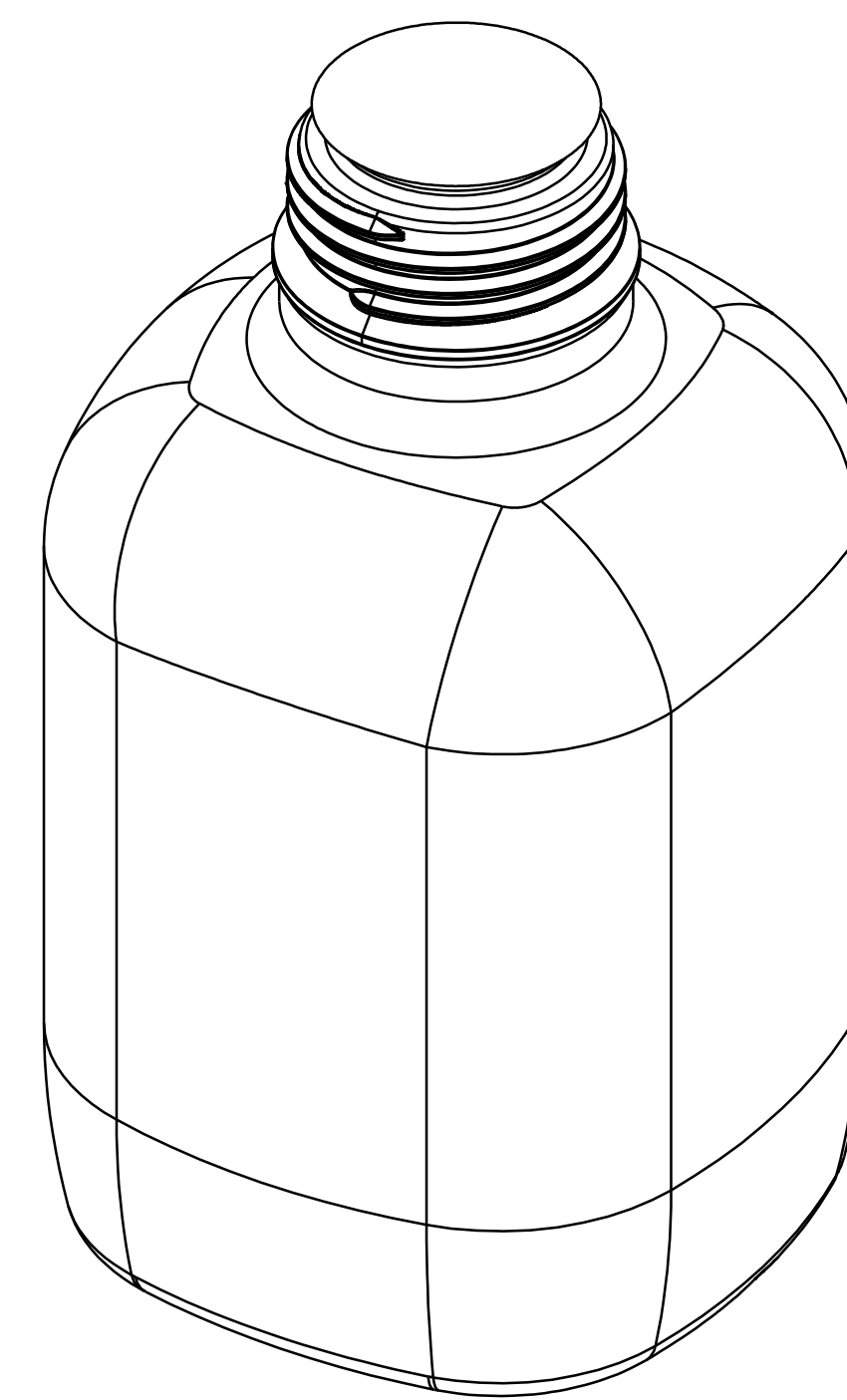
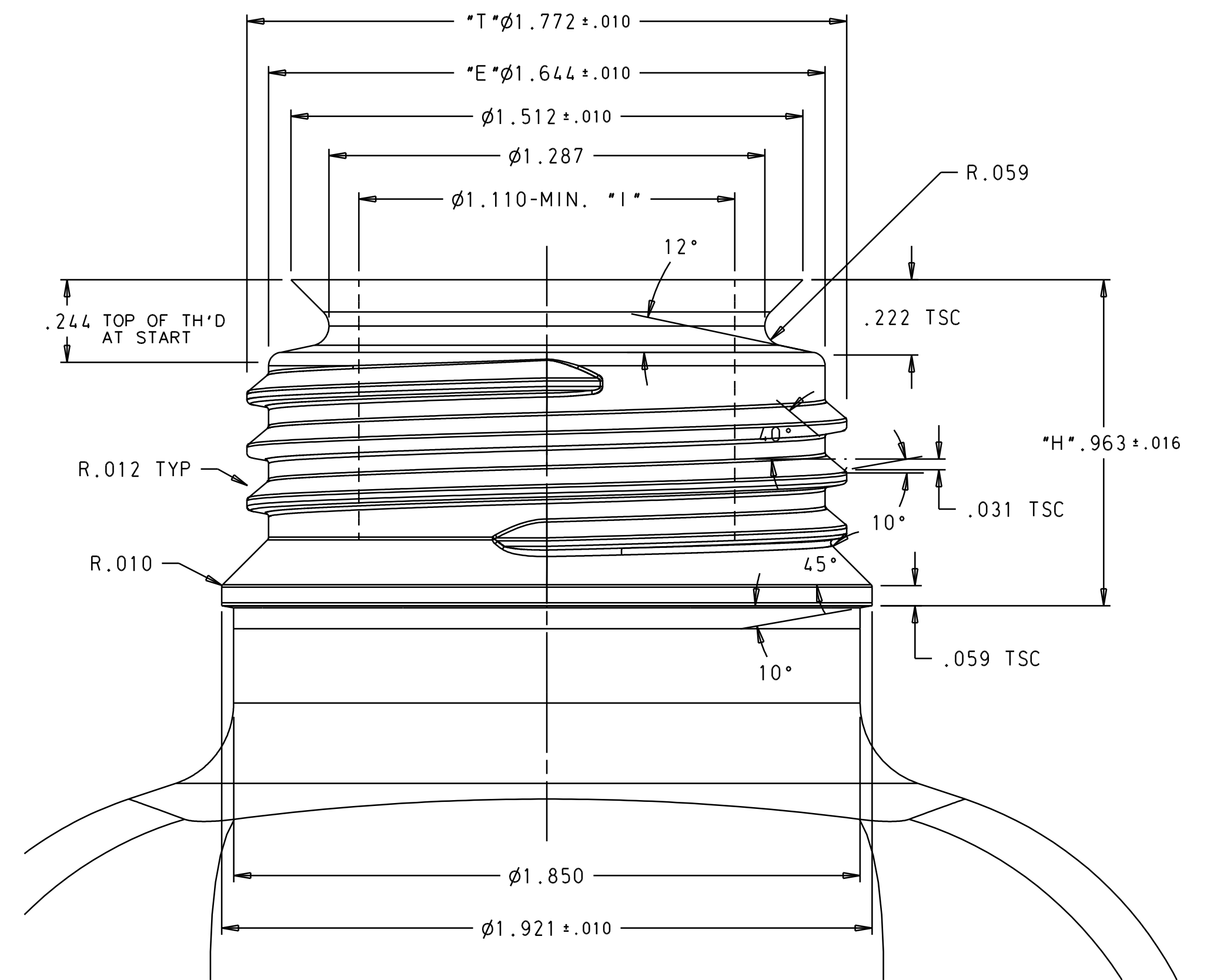

- NOTES:
- 1) MATERIAL: HDPE
 - 2) WEIGHT: 85.0 ± 2.0 GRAMS
 - 3) OVERFLOW: 1122.6 ± 20 cc

THIS DESIGN IS CREATED EXCLUSIVELY FOR USE BY HEISE IND., INC. AND IS COPYRIGHTED MATERIAL AND IS SUBJECT TO THE COPYRIGHT LAWS OF THE U.S.A., CANADA, AND MEXICO. ANY USE OF THIS MATERIAL OTHER THAN THAT SPECIFIED BY HEISE IND., INC. IS PROHIBITED © 2010

A450A0	1st	1	1 LITER SQUARE	
JOB No.	SET	CAVITY No.	PRODUCT DRAWING WITH 45 mm FINISH	
CAD FILE INFORMATION:			REVISIONS	
PROJECT: A450A0			DRW'N. BY: C.J.C. DATE: 8-4-10 SCALE FULL SHEET OF	
DRAWING: A450A0PD1			CHK'D. BY: C.J.C. DATE: 8-4-10 DWG.# D-45263	
MODEL FILE: A450A0_DESIGN_CHUCK				
LIBRARY: -----; LIBRARY-				

HEISE
INDUSTRIES INC
196 Commerce Street
East Berlin
Connecticut 06023 U.S.A.
1-800-928-MOLD