

THIS DESIGN IS CREATED EXCLUSIVELY FOR USE BY HEISE IND. INC. AND IS COPYRIGHTED MATERIAL AND IS SUBJECT TO THE COPYRIGHT LAWS OF THE U.S.A., CANADA, AND MEXICO. ANY USE OF THIS MATERIAL OTHER THAN THAT SPECIFIED BY HEISE IND. INC. IS PROHIBITED © 2010

38 MM DG NECK FINISH  
SCALE: 3:1

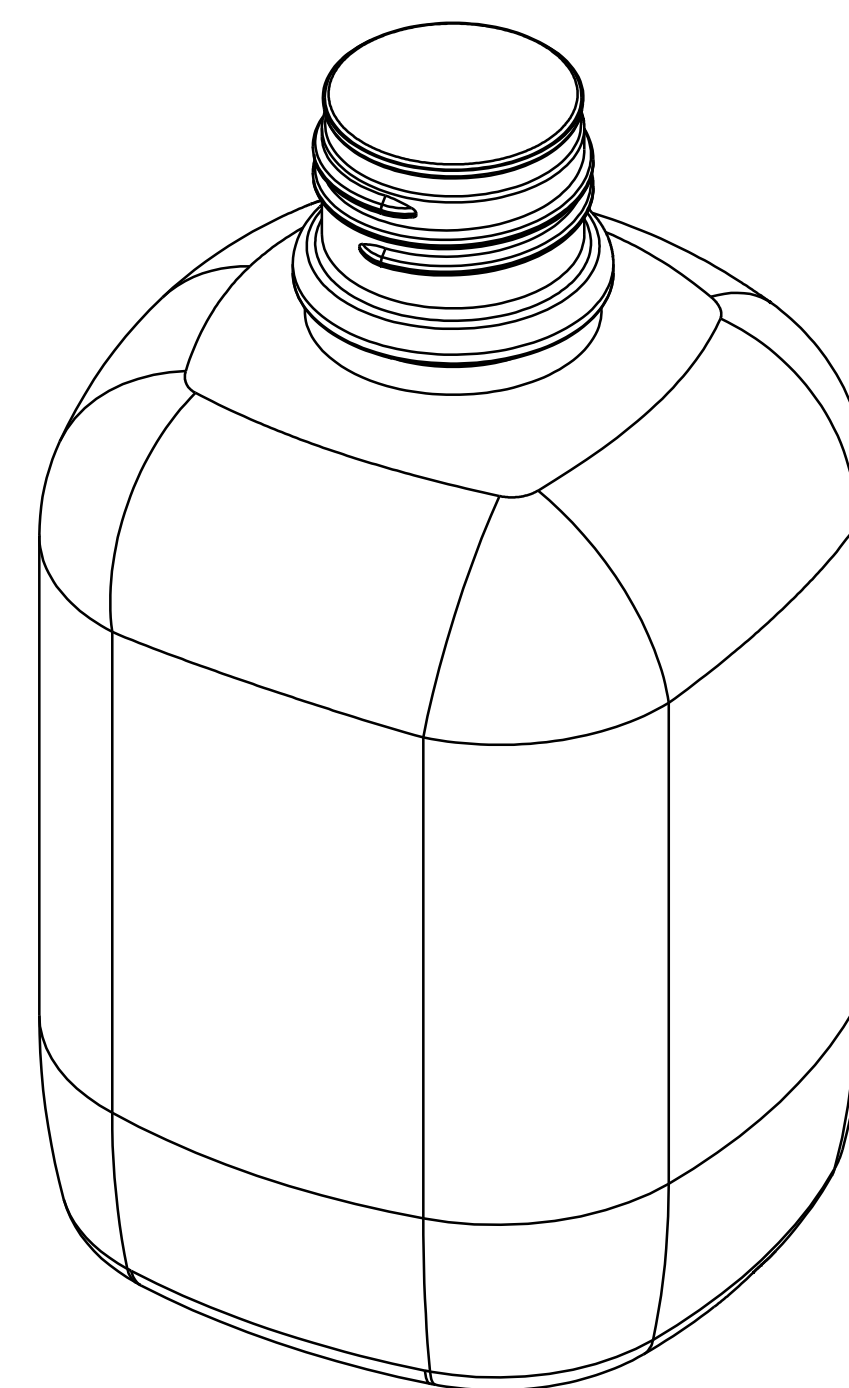
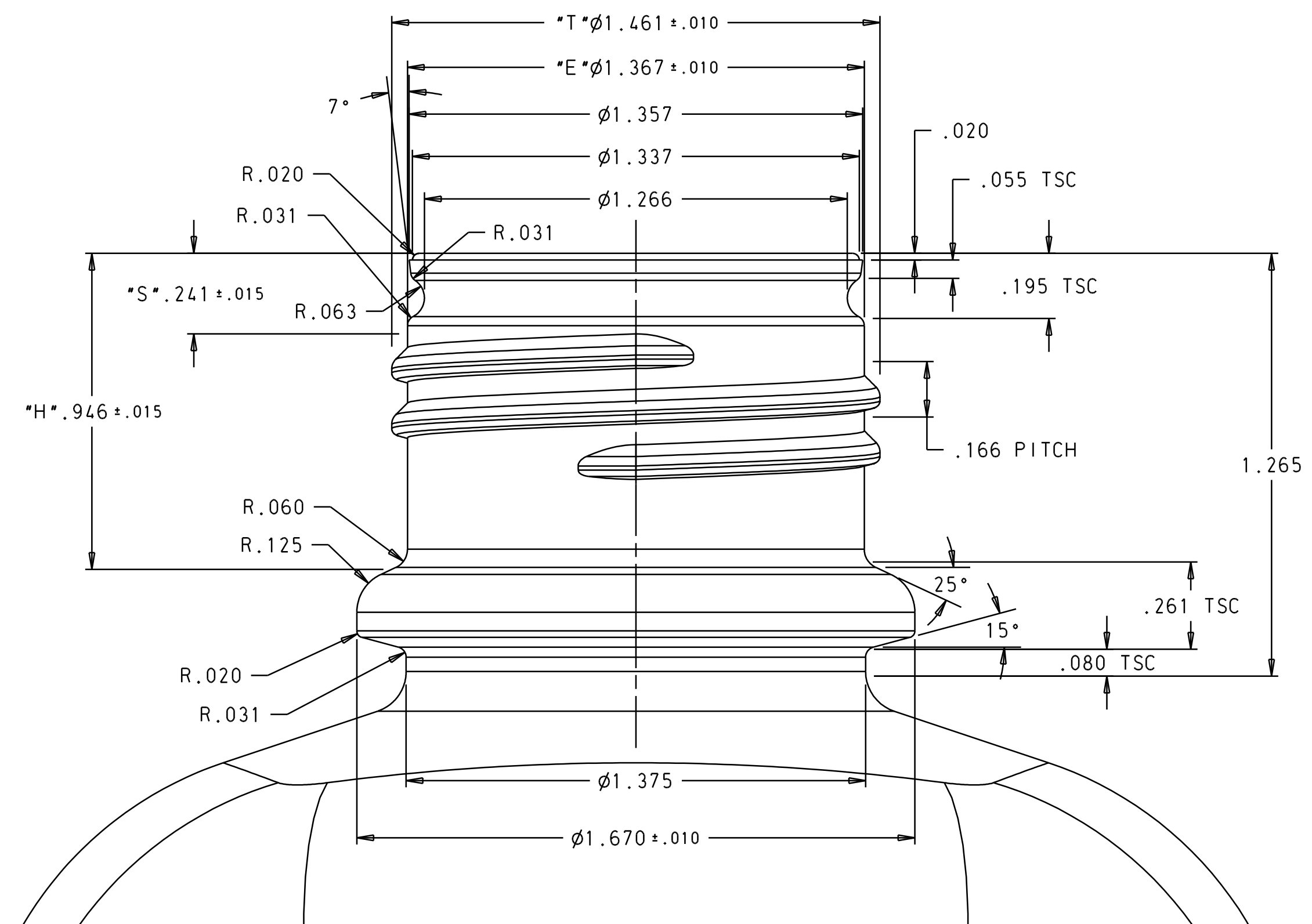

- NOTES:
- 1) MATERIAL: HDPE
  - 2) WEIGHT: 85.0 ± 2.0 GRAMS
  - 3) OVERFLOW: 1107.0 ± 20 cc

A450A0	1st	1	1 LITER SQUARE	
JOB No.	SET	CAVITY No.	PRODUCT DRAWING WITH 38 mm FINISH	
CAD FILE INFORMATION:			REVISIONS	
PROJECT: A450A0			DRW'N. BY: C.J.C. DATE: 8-4-10 SCALE FULL SHEET OF	
DRAWING: A450A0PD2			CHK'D. BY: C.J.C. DATE: 8-4-10 DWG.# D-45264	
MODEL FILE: A450A0_DESIGN_CHUCK				
LIBRARY: -----; LIBRARY-				

**HEISE**  
**INDUSTRIES INC**  
196 Commerce Street  
East Berlin  
Connecticut 06023 U.S.A.  
1-800-928-MOLD